

Chapter 10: Thermal Noise and System Noise Figure

In a warm resistor (*i.e.*, one above absolute zero degrees Kelvin) free electrons move about in thermally excited motion. This gives rise to a noise voltage that appears across the resistor's terminals. This noise was first analyzed in 1927 by J.B. Johnson of the Bell Telephone Laboratories, and it goes by the names *thermal noise*, *white Gaussian noise*, *Johnson noise* and *kTB noise*. This chapter describes a simple model for thermal noise and describes how it is treated in system analysis.

Each thermally excited electron contributes to the noise in the resistor. There are a large number of such electrons, each moving very rapidly and each contributing a small amount of noise power. As a result, thermal noise is the result of a large number of noise voltages, and the central limit theorem implies that the total noise is Gaussian. Assuming a constant resistance and temperature, the noise process is stationary.

The noise generated by the randomly moving electrons can be analyzed and modeled by using thermodynamics. It can be shown (see H. Nyquist, "Thermal Agitation of Electric Charge in Conductors", *Physical Review*, Vol. 32, pp 110-113, 1928a) that the noise generated by a resistance of R ohms at a temperature of T degrees Kelvin (to convert degrees Celsius to degrees Kelvin simply add 273; degrees Kelvin = degrees Celsius + 273) has a power spectrum that is accurately represented by

$$\mathcal{S}_{n_e}(\omega) = \frac{N_0}{2} \left[\frac{|\omega|/\omega_0}{\exp(|\omega|/\omega_0) - 1} \right], \quad (10-1)$$

where bandwidth parameter ω_0 is given by

$$\omega_0 = 2\pi(kT/\hbar). \quad (10-2)$$

The quantities k , \hbar and $N_0/2$ are the *Boltzmann's*, *Planck's* and the *spectral intensity parameter*,

respectively, and their numerical values are

$$k \approx 1.38 \times 10^{-23} \text{ joules/degree Kelvin}$$

$$\hbar \approx 6.63 \times 10^{-34} \text{ joule - seconds} \quad (10-3)$$

$$\frac{N_0}{2} = 2kTR \approx 2.76 \times 10^{-23} TR \text{ watts-Ohm/Hz.}$$

At room temperature, $T = 290^\circ$ Kelvin, and

$$\omega_0 \approx 12\pi \times 10^{12} \text{ radians/second} \quad (10-4)$$

$$\frac{N_0}{2} \approx 8 \times 10^{-21} R \text{ watt-ohm/Hz.}$$

The quantity $\omega_0/2\pi = kT/\hbar$ can be approximated by the reciprocal of the mean relaxation time of free electrons in the resistor.

As can be seen from (10-4), the bandwidth ω_0 of the process is very large. Over the frequency range of interest to the communication engineer (from audio to the microwave bands), Equation (10-1) can be approximated as

$$S_{n_e}(\omega) \approx \frac{N_0}{2} = 2kTR, \text{ watts - Ohm/Hz,} \quad (10-5)$$

a flat spectral density. Figure 10-1 depicts a commonly used model for a noisy resistor.

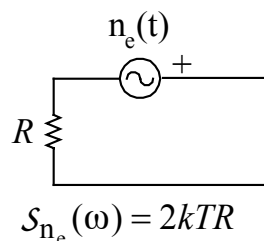
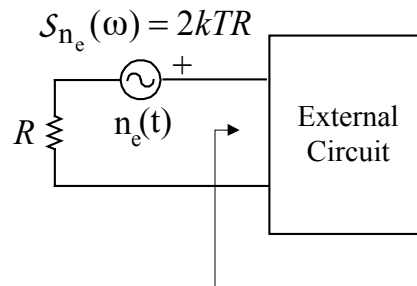

Figure 10-1: Model for a warm, noisy, resistor.



Z_{in} is driving point impedance of circuit.
Max power transfer occurs when $Z_{in} = R$.

Figure 10-2: Warm resistor supplying noise power to an external circuit.

When connected in a circuit, a warm resistor delivers noise power to the circuit (see Figure 10-2). Within a one-sided bandwidth of B Hz, we want to determine the *maximum* amount of noise power that the resistor can deliver to the circuit. That is, assume that the external circuit acts like an ideal bandpass filter with a magnitude response illustrated by Figure 10-3 (the circuit only absorbs power in the frequency range illustrated by the figure). We want to find the amount of noise power that the external circuit absorbs. From circuit theory, we know that maximum power transfer occurs when the source is impedance matched to the load; maximum power is transferred when $Z_{in} = R$, where Z_{in} is the impedance seen looking into the external circuit. When impedance matched, the voltage across the terminals of the external circuit will be $n_e(t)/2$. Since (10-5) is a double-sided spectrum (power over both negative and positive frequencies must be added, or the power over the positive frequencies must be doubled), the amount of noise power, in a bandwidth of B Hz, absorbed by the external circuit is

$$P_{\text{watts}} = 2 \left(\frac{1}{2\pi} \right) \int_{\text{bandwidth of } 2\pi B \text{ rad/sec}} \frac{(2kTR/4)}{R} d\omega = kTB \quad (10-6)$$

watts, where the integration is over the positive frequency side of Figure 10-3. So, from the warm resistor, within a bandwidth of B Hz, we see that the *maximum available noise power*

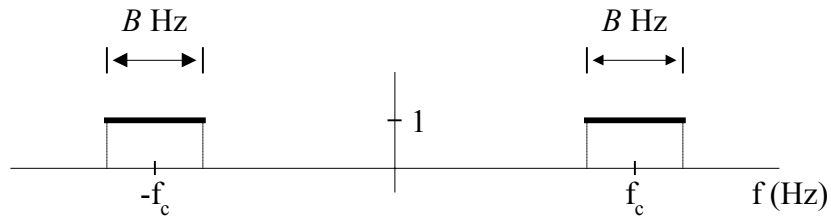

Figure 10-3: Frequency response of the external circuit illustrated in Figure 10-2.

(sometimes called the *available power*) is kTB watts, a value that does not depend on the resistance R but is proportional to bandwidth B . Because of (10-6), thermal noise is sometimes called kTB noise.

Often, small amounts of power are specified in dB relative to one milliwatt; the units used are dBm. So 1/10 milliwatt would be -10dBm, 1 milliwatt would be 0 dBm and 10 milliwatts would be +10dBm, etc. In units of dBm, the noise power delivered by a resistor of R ohms at T degrees Kelvin in a bandwidth of B Hz is

$$P_{\text{dBm}} = 10 \text{ Log} \frac{P_{\text{watts}}}{.001} = 10 \text{ Log} \frac{kTB}{.001}. \quad (10-7)$$

Example 10-1: Convert the power level of 13 dBm to watts. From the definition given above, we can write $13 = 10 \log(P_{\text{watts}}/.001)$, a result that leads to $P_{\text{watts}} = 20$ mW (milliwatts). This result can be obtained mentally without the use of logarithms. Since 0dBm is 1 mW, we know that 10dBm is 10 mW. Also, we know that doubling the power is equivalent to a 3dB increase in power; so 13dBm is twice the power of 10dBm. This leads to the conclusion that 13dBm is 20 mW.

Example 10-2: Determine the spectral density of the noise $v(t)$ that exists across the capacitor in Figure 10-4. The circuit model is given to the right; basically, n_e is driving an RC series circuit. The voltage across the capacitor (*i.e.*, the output voltage) has the power spectrum

$$S_v(\omega) = |H(j\omega)|^2 S_{n_e}(\omega) = \frac{2kTR}{1 + \omega^2 R^2 C^2} = \frac{kT}{C} \left[\frac{2(1/RC)}{\omega^2 + (1/RC)^2} \right], \quad (10-8)$$

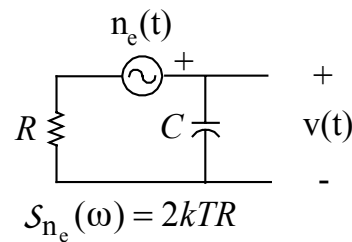

Figure 10-4: Noisy resistor in parallel with a capacitor.

and the autocorrelation of the output voltage is given as

$$R_v(\tau) = \frac{kT}{C} e^{-|\tau|/RC} . \quad (10-9)$$

For the circuit depicted by Fig. 10-4, the impedance looking into the output terminals is

$$Z(s) = \frac{(1/sC)R}{R + 1/sC} = \frac{R}{1 + RCs} . \quad (10-10)$$

Combine this with (10-8) to see that ($Re[\]$ denotes the real part)

$$S_v(\omega) = 2kT Re[Z(j\omega)] . \quad (10-11)$$

Suppose an impulse current generator $i(t) = \delta(t)$ is connected to the output terminals of the circuit depicted by Fig. 10-4. The driving impulse $i(t)$ would generate a voltage of

$$z(t) = \mathcal{L}^{-1}[Z(s)] = \frac{1}{C} e^{-t/RC} U(t) \quad (10-12)$$

across the output terminals. Voltage $z(t)$ is an impulse response if one considers current $i(t) = \delta(t)$ as the input and voltage $z(t)$ as the output. For $\tau \geq 0$, $z(\tau)$ can be used to express the “ $\tau \geq 0$

half" of R_v as

$$R_v(\tau) = kT z(\tau), \quad \tau \geq 0, \quad (10-13)$$

a result that is verified by (10-9).

The fact that output autocorrelation R_v and spectrum S_v can be written in terms of complex impedance $Z(j\omega)$ and impulse response $z(\tau)$ is no fluke. Instead, these observations are a consequence of the *Nyquist Noise Theorem*.

Nyquist Noise Theorem

Consider a passive, reciprocal circuit composed of linear R, L and C components. Denote by $v(t)$ the thermal noise voltage that appears across any two terminals a and b ; let $Z(s)$ be the complex impedance looking into these terminals. See Figure 10-5. The power spectrum of thermal noise $v(t)$ is

$$S_v(\omega) = 2kT \operatorname{Re}[Z(j\omega)]. \quad (10-14)$$

For $\tau > 0$, the autocorrelation of $v(t)$ is

$$R_v(\tau) = kT \mathcal{L}^{-1}[Z(s)], \quad \tau > 0, \quad (10-15)$$

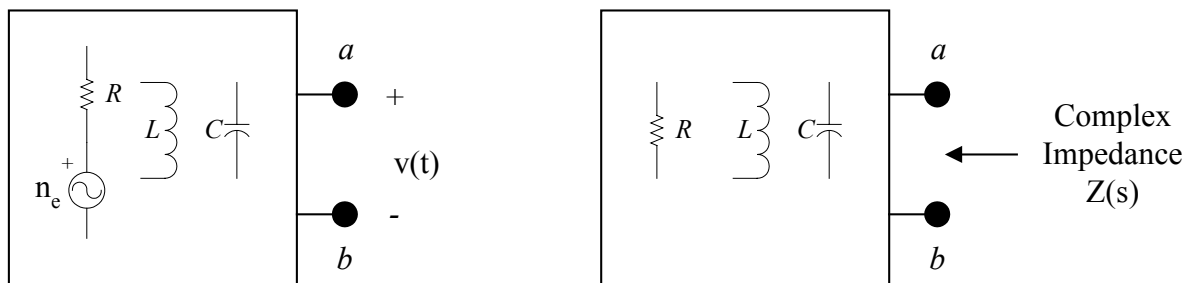

Fig. 10-5: a) Passive RLC circuit with one, or more, noisy resistors. Source n_e models thermal noise voltage in R . Voltage $v(t)$ is the output thermal noise after filtering by the circuit. b) $Z(s)$ is the complex impedance looking into the circuit terminals.

where $\mathcal{L}^{-1}[Z(s)]$ is the one-sided, causal Laplace transform inverse of the complex driving point impedance $Z(s)$. Note that $R_v(\tau)$ generally contains an impulse function when complex impedance $Z(s)$ contains an additive pure resistance component or when $Z(s)$ is purely resistive. Also, use the fact that $R_v(\tau)$ is an even function to obtain the autocorrelation for $\tau < 0$.

Proof: See A. Papoulis, S. Pillai, *Probability, Random Variables and Stochastic Processes*, Fourth Edition, McGraw Hill, 2002, p. 452.

RMS Value of Noise Voltage in a B Hz Bandwidth

Denote as $v_n(t)$ the result of filtering $n_e(t)$ by the band-pass filter depicted by Figure 10-3; that is, v_n is the original signal limited to a B Hz bandwidth (one sided bandwidth). We denote as V_{RMS} the RMS value of this band-limited signal. $v_n(t)/2$ is the band-limited noise voltage that an external circuit “sees” across its terminals under impedance-matched conditions; $V_{\text{RMS}}/2$ is the RMS value of this voltage. Under impedance matched conditions, $(V_{\text{RMS}}/2)^2/R$ is the power absorbed by the external circuit; with (10-6), we can write

$$(V_{\text{RMS}} / 2)^2 / R = kTB \quad (10-16)$$

so that

$$V_{\text{RMS}} = \sqrt{4RkTB} . \quad (10-17)$$

is the RMS value of the voltage v_n (which is n_e filtered to a one-sided bandwidth of B Hz).

Example 10-3: Consider Figure 10-2 where the resistor operates at a temperature of 17°C , and the external circuit has a frequency response depicted by Figure 10-3 with a bandwidth of $B = 10\text{kHz}$.

- a) In watts and dBm, calculate the thermal noise power that the warm resistor delivers to the external circuit under impedance matched conditions. First, we must compute the absolute temperature $T = 17^\circ + 273^\circ = 290^\circ$ (degrees Kelvin). Then, we can use (10-6) and (10-7) to

compute

$$P_{\text{watts}} = kTB = (1.38 \times 10^{-23})(290)(1 \times 10^4) = 4 \times 10^{-17} \text{ watts}$$

$$P_{\text{dBm}} = 10 \text{ Log} \frac{4 \times 10^{-17}}{.001} = -140 \text{ dBm}$$

b) Calculate V_{RMS} if the impedance-matched, band-limited external circuit has a driving point impedance of 100 ohms. We use the value $kTB = 4 \times 10^{-17}$ in Equation (10-17) to obtain the value

$$V_{\text{RMS}} = \sqrt{4RkTB} = \sqrt{4(100)(4 \times 10^{-17})} = .1265 \mu\text{V (micro-volts)}$$

for the RMS value of n_e filtered to a one-sided bandwidth of B Hz.

Noise in Receiving Antennas

At resonance, the impedance measured at the terminals of a radio frequency communication antenna is real valued (pure resistance). The resistance that appears at the terminals is the sum of a *radiation resistance* and an *ohmic resistance*. For commonly used antennas, the radiation resistance is approximately 50 Ω for a quarter-wave vertical over a ground plane, 72 Ω for a half-wave dipole in free space or 300 Ω for a folded half-wave dipole in free space. From a transmitter, power supplied to an antenna is “absorbed” by these resistances; actually, the power “absorbed” by the radiation resistance is radiated into space, and power “absorbed” by the ohmic resistance is turned into heat (it is wasted). Usually, an antenna’s ohmic losses are small compared to the power that is radiated (the radiation resistance is much larger than the ohmic resistance). An exception to this occurs in antennas with physical dimensions that are small compared to a wavelength (as is sometimes the case for antennas designed for low frequencies - an automobile antenna for the AM band, for example); for these cases, the ohmic losses may dominate.

Random noise appears across the terminals of a receiving antenna. This noise comes

from two sources: (1) thermal noise generated in the antenna's ohmic resistance, and (2) noise received ("picked up") from other sources (both natural and man-made). Often, the antenna noise is represented *as though it were thermal noise generated in a fictitious resistance, equal to the radiation resistance, at a temperature T_A that would account for the actual delivered noise power*. That is, we model the antenna as a warm resistor, with value equal to the radiation resistance, operating at some temperature of T_A degrees Kelvin. T_A is the value at which the fictitious resistor would deliver an amount of noise power equal to what the antenna delivers. T_A is called the *noise temperature* of the antenna.

Example 10-4: Suppose that a 200Ω antenna exhibits an RMS noise voltage of $V_{\text{RMS}} = .1 \mu\text{V}$ at its terminals, when measured in a bandwidth of $B = 10^4$ Hz (*i.e.*, an RMS volt meter, with a bandwidth of 10^4 Hz, indicates $.1 \mu\text{V}$ when connected to the antenna). What is the antenna noise temperature T_A ? We assume that the 200Ω impedance does not change significantly over the 10kHz bandwidth. From (10-17), we compute

$$V_{\text{RMS}}^2 = 4kT_A RB,$$

a result that leads to

$$T_A = \frac{V_{\text{RMS}}^2}{4kRB} = \frac{(10^{-7})^2}{4(1.38 \times 10^{-23})(200)(10^4)} = 90.6^\circ \text{ Kelvin}.$$

Hence, from a noise standpoint, the antenna looks like a 200Ω resistor at 90.6° K . Temperature T_A does not depend on bandwidth (why?).

Effective Noise Temperature of a Broadband Noise Source

A broadband noise source (any object that generates electrical noise) can be characterized by specifying its *effective noise temperature*. Suppose a source, within a bandwidth of B Hz, delivers P_a watts to an impedance-matched load. As is suggested by (10-6),

we define the *effective noise temperature* of the source as

$$T_0 \equiv P_a / kB \text{ degrees Kelvin.} \quad (10-18)$$

This usage assumes that the noise spectrum is flat over the bandwidth of interest. For this case, temperature T_0 will be independent of B ; the noise power P_a will depend on B , and bandwidth should cancel out of (10-18).

A source may have an output noise spectrum with a shape that depends on frequency. However, the source may still be almost “flat” over a bandwidth $B = \Delta\omega/2\pi$ of interest. For example, this could be the case for warm resistors that are connected in a circuit with capacitors and/or inductors. For this case, the effective noise temperature T_0 is a function of frequency. Next, we consider such a case.

Let $S_v(\omega)$ denote the output noise power spectrum of a source. In a bandwidth of $\Delta\omega$ radians/second, we have

$$\text{Power in } \Delta\omega \text{ Bandwidth} \approx S_v(\omega) \frac{\Delta\omega}{2\pi} \text{ watts,} \quad (10-19)$$

a frequency-dependent quantity (this assumes the source is “flat” over bandwidth $\Delta\omega$). Let $R(\omega)$ denote the resistive component of the source output impedance. Now, $T_0(\omega)$, the effective noise temperature of the source, must satisfy

$$2k T_0(\omega) R(\omega) \frac{\Delta\omega}{2\pi} = S_v(\omega) \frac{\Delta\omega}{2\pi}, \quad (10-20)$$

so that

$$T_{\theta}(\omega) = \frac{\mathbf{S}_v(\omega)}{2kR(\omega)} \quad (10-21)$$

Equation (10-21) can be obtained from (10-18). Within a bandwidth $B = \Delta\omega/2\pi$ (over which \mathbf{S}_v is “flat”), the power delivered to an impedance matched load of R ohms is

$$P_a(\omega) = 2 \frac{\mathbf{S}_v(\omega)/4}{R(\omega)} \left(\frac{\Delta\omega}{2\pi} \right). \quad (10-22)$$

Substitute (10-22) into (10-18) to obtain

$$T_{\theta}(\omega) \equiv P_a(\omega)/kB = \frac{2 \frac{\mathbf{S}_v(\omega)/4}{R(\omega)} \left(\frac{\Delta\omega}{2\pi} \right)}{k \frac{\Delta\omega}{2\pi}} = \frac{\mathbf{S}_v(\omega)}{2kR(\omega)}, \quad (10-23)$$

a result that is equivalent to (10-21).

Example 10-5: Consider the RLC network depicted by Fig.10-6. R_1 is at T_1 degrees Kelvin, and R_2 is at T_2 degrees Kelvin. If the network is used as a broadband noise source with output across the terminals, what is the effective noise temperature of the source?

Solution: The noise spectrum across resistor R_1 is

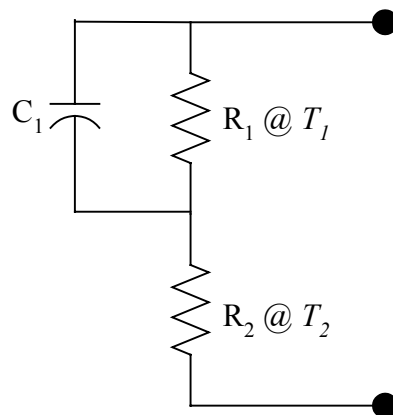

Figure 10-6: Noise source for Example 10-5.

$$S_{v_1}(\omega) = 2k T_1 \operatorname{Re} \left[\frac{R_1 / j\omega C_1}{R_1 + 1 / j\omega C_1} \right] = 2k T_1 \frac{R_1}{1 + \omega^2 R_1^2 C_1^2}.$$

Now, add this to the spectrum of the noise power generated by R_2 . In a $\Delta\omega$ bandwidth, the source generates

$$\begin{aligned} P_a &= 2k \left[\frac{T_1 R_1}{1 + \omega^2 R_1^2 C_1^2} + T_2 R_2 \right] \frac{\Delta\omega}{2\pi} \\ &= 2k \left[\frac{T_1 R_1 + T_2 R_2 (1 + \omega^2 R_1^2 C_1^2)}{1 + \omega^2 R_1^2 C_1^2} \right] \frac{\Delta\omega}{2\pi} \end{aligned} \quad (10-24)$$

watts. The resistive component of the source output impedance is

$$R = R_2 + \operatorname{Re} \left[\frac{R_1 / j\omega C_1}{R_1 + 1 / j\omega C_1} \right] = \frac{R_2 (1 + \omega^2 R_1^2 C_1^2) + R_1}{1 + \omega^2 R_1^2 C_1^2}.$$

At equivalent temperature T_0 , this resistance generates the same power as (10-24) so

$$2k T_0 \left[\frac{R_2 (1 + \omega^2 R_1^2 C_1^2) + R_1}{1 + \omega^2 R_1^2 C_1^2} \right] \frac{\Delta\omega}{2\pi} = 2k \left[\frac{T_1 R_1 + T_2 R_2 (1 + \omega^2 R_1^2 C_1^2)}{1 + \omega^2 R_1^2 C_1^2} \right] \frac{\Delta\omega}{2\pi},$$

or

$$T_0 = \frac{T_1 R_1 + T_2 R_2 (1 + \omega^2 R_1^2 C_1^2)}{R_1 + R_2 (1 + \omega^2 R_1^2 C_1^2)}. \quad (10-25)$$

Effective Input Noise Temperature of an Amplifier/Network

Within a bandwidth of B Hz, a noise source will supply $P_{ns} = kT_0 B$ watts, where T_0 is the

effective noise temperature of the source. Suppose that this source is connected to a noiseless amplifier/network (a fictitious amplifier that generates no internal noise) with power gain G_a . Then, the noise power output of the amplifier is

$$P_{no} = G_a k T_0 B \quad (10-26)$$

watts. Now, suppose that the amplifier is not noiseless; within a one-sided bandwidth of B Hz, suppose that it generates P_{ne} watts of noise so that the total output noise power is

$$P_{no} = G_a k T_0 B + P_{ne} \quad (10-27)$$

watts (as measured in a B Hz bandwidth), a result depicted by Figure 10-7. Write (10-27) as

$$P_{no} = G_a k (T_0 + T_e) B \quad (10-28)$$

$$T_e \equiv \frac{P_{ne}}{G_a k B}$$

The quantity T_e is called the *effective input noise temperature* of the amplifier. By using T_e , we have referenced the internally generated noise to an input source. That is, the noise from an input source at temperature T_e would be amplified and show up as P_{ne} watts of output noise, a result depicted by Figure 10-8. In the development of (10-28), we have assumed that the internally generated noise has a spectrum that is approximately flat over the bandwidth B of

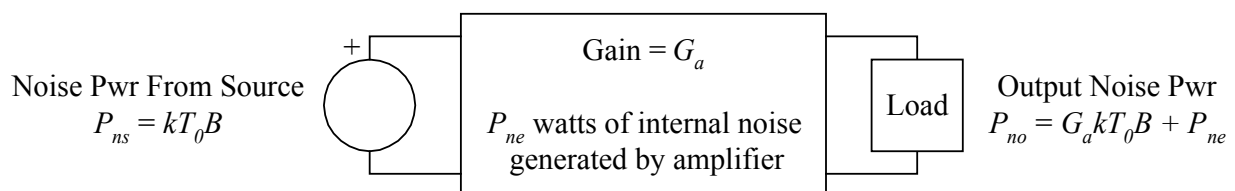

Figure 10-7: Amplifier with P_{ns} watts of input noise power. Amplifier generates internally P_{ne} watts of additional noise power.

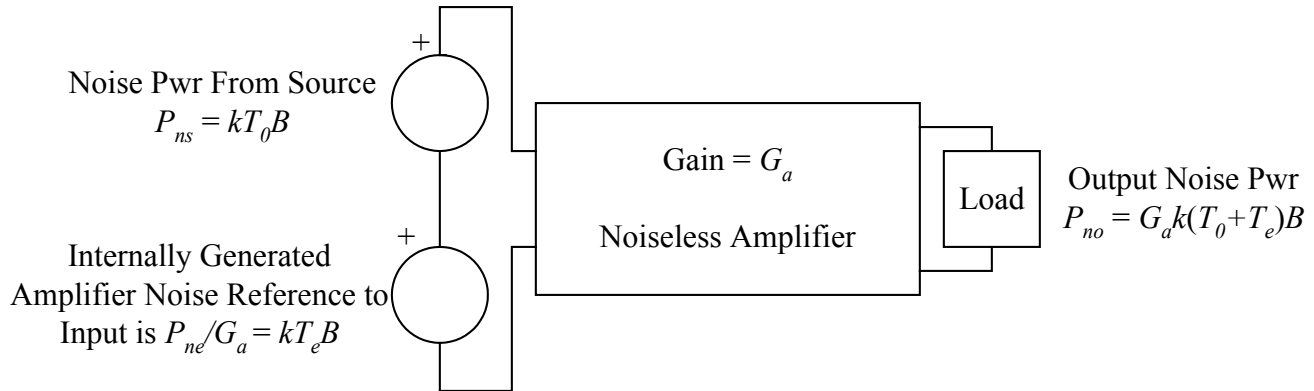

Figure 10-8: P_{ne} watts of internally-generated amplifier noise can be referenced to the input as a source at temperature T_e .

interest; hence, P_{ne} is proportional to bandwidth, and T_e would be largely independent of bandwidth. However, P_{ne} is allowed to vary slowly with frequency, so temperature T_e may be a function of frequency. As will be seen in what follows, the ability to reference internally-generated noise to an amplifier input is very useful when it comes to analyzing the noise properties of a chain of noisy amplifiers/networks. Also, effective input noise temperature is a commonly used method for specifying the noise performance of low noise amplifiers (LNA) in the TVRO market.

Signal-to-Noise Ratio (SNR)

Signal-to-noise ratio (SNR) is a ratio of signal power to noise power at a port (pair of terminals). More specifically, it is the ratio of signal power *in a specified bandwidth* to noise power *in the same bandwidth*. Note that bandwidth must be specified, or implied, when discussing/computing an SNR. Often, SNR is given in dB; let P_s and P_n denote signal and noise powers, respectively. In terms of dB, we write

$$\text{SNR(dB)} = 10 \text{Log}_{10} \left(\frac{P_s}{P_n} \right). \quad (10-29)$$

As a signal passes through a cascade of amplifier stages or devices, the SNR decreases after each stage because noise is added in each stage. However, in many applications involving a cascade

of low-noise, high-gain stages, the overall output SNR is determined by the input SNR and the noise properties (*i.e.*, the noise figure) of the first stage alone; that is, stages after the first influence very little the overall system SNR.

System Noise Factor/Figure

Noise is added to a signal as it passes through a system, such as an amplifier. Thermal noise, which is in all practical electronic systems, is the most predominant noise in many (but not all!) systems. Since the system amplifies/attenuates its input signal and noise equally, and more noise is added by the system itself, the signal-to-noise ratio (SNR) at the output is lower than the signal to noise ratio on the input. System *noise factor* and *noise figure* characterize the extent of this degradation as the signal passes through the system.

Let $(\text{SNR})_{\text{IN}}$ and $(\text{SNR})_{\text{OUT}}$ denote the input and output signal-to-noise ratios, respectively, of the system (these are specified in the same bandwidth). Let P_{si} and P_{ni} denote the input signal and noise powers, respectively. Likewise, denote as P_{so} and P_{no} as the output signal and noise powers, respectively. Then, *system noise factor* is defined as

$$F = (\text{SNR})_{\text{IN}} / (\text{SNR})_{\text{OUT}} = \frac{P_{\text{si}}/P_{\text{ni}}}{P_{\text{so}}/P_{\text{no}}} = \frac{P_{\text{no}}}{(P_{\text{so}}/P_{\text{si}})P_{\text{ni}}} = \frac{P_{\text{no}}}{G_a P_{\text{ni}}}, \quad (10-30)$$

where $G_a = P_{\text{so}}/P_{\text{si}}$ is the *power gain* of the system ($F > 1$ in real-world, noisy systems. However, the smaller F is the better.). Now, $P_{\text{no}} = G_a P_{\text{ni}} + P_{\text{ne}}$, where $P_{\text{ne}} = G_a k T_e B$ is noise added by the amplifier/device. Combine this with (10-30) to obtain

$$F = \frac{P_{\text{no}}}{G_a P_{\text{ni}}} = \frac{G_a P_{\text{ni}} + G_a k T_e B}{G_a P_{\text{ni}}} = 1 + \frac{k T_e B}{P_{\text{ni}}}. \quad (10-31)$$

Equation (10-31) shows that F is dependent on input noise power P_{ni} .

Often, system noise factor F is converted to Decibels (dB). In this case, we use the name *system noise figure* and write

$$NF = 10\text{Log}_{10}[F] = 10\text{Log}_{10}\left[\frac{(\text{SNR})_{\text{IN}}}{(\text{SNR})_{\text{OUT}}}\right], \quad (10-32)$$

where the units are Decibels ($NF > 0$ in real-world, noisy systems). Again, the smaller the better when it comes to NF. The advantage of using NF and a logarithmic scale is evident in

$$10\text{Log}_{10}[(\text{SNR})_{\text{OUT}}] = 10\text{Log}_{10}[(\text{SNR})_{\text{IN}}] - NF, \quad (10-33)$$

using the fact that, when expressing noise figure in dBs, one can subtract NF from the input SNR to obtain the output SNR.

As discussed previously, SNR depends on bandwidth. In (10-30), $(\text{SNR})_{\text{in}}$ and $(\text{SNR})_{\text{out}}$ are specified in the same bandwidth B , and they are both proportional to B . Hence, bandwidth cancels out of (10-30), and device/system noise factor and noise figure are independent of bandwidth. However, as shown by (10-31), noise factor/figure of a device is dependent on input noise power (equivalently, F and NF are dependent on source temperature).

In product literature and on technical data sheets, it is common for manufactures to specify noise factor F and/or noise figure NF . For example, in their *Diode and Transistor Designer's Catalog 1982-1983*, Hewlett Packard (now Agilent Technologies) advertises a typical NF of 1.6 dB for their 2N6680 microwave GaAs FET operating at 4 GHz. As can be seen from (10-31), device/system F (and NF) depend on source noise power P_{in} . So, one may ask, what source noise power (or source temperature) did Agilent use when they specified the 2N6680's noise figure?

If Agilent followed the accepted norm, they specified the above-mentioned device noise figure relative to a *standard noise source*, a resistor at room temperature $T_0 = 290^\circ$ Kelvin. Generally, one can assume that a device/system is connected to a standard noise source at $T_0 = 290^\circ$ Kelvin when noise factor/figure is measured and specified. When the noise factor of a system/device is specified, it is common to use (10-30) with $P_{\text{ni}} = kT_0B$, where $T_0 = 290^\circ$ Kelvin.

Example 10-6: The noise figure of a perfect (hypothetical) system would be zero dB; such a system would not add any noise to a signal passing through it. On the other hand, suppose an amplifier has a NF of 2 dB, and it is amplifying input signal and noise with an input SNR of 10 dB. For this case, use (10-33) to compute the output SNR as 8 dB.

Example 10-7: Suppose an amplifier is operating with an input signal power of 2×10^{-10} watts, an input noise power of 2×10^{-18} watts and a power gain of 1×10^6 . Furthermore, suppose the amplifier itself generates an output noise power of 6×10^{-12} watts. Calculate a) input SNR in dB, b) output SNR in dB, and c) noise factor and noise figure.

a) The input SNR is

$$(\text{SNR})_{\text{IN}} = \frac{2 \times 10^{-10}}{2 \times 10^{-18}} = 1 \times 10^8.$$

Equivalently, the input SNR is 80 dB.

b) The output noise power is the sum of the internally-generated noise and the input noise, after amplification. Hence, the total output noise power is

$$\text{Noise Output Power} = 10^6(2 \times 10^{-18}) + 6 \times 10^{-12} = 8 \times 10^{-12} \text{ watts}.$$

The output signal power is

$$\text{Signal Output Power} = 10^6(2 \times 10^{-10}) = 2 \times 10^{-4}.$$

Hence, the output signal-to-noise ratio is

$$(\text{SNR})_{\text{OUT}} = \frac{2 \times 10^{-4}}{8 \times 10^{-12}} = 2.5 \times 10^7.$$

Equivalently, the output SNR is about 74 dB.

c) The ratio of the result for parts a) and b) produce a system noise factor of $F = 1 \times 10^8 / 2.5 \times 10^7 = 4$, or a system noise figure of $NF = 10 \log(4) = 6$ dB.

Relationship Between System Noise Factor and Temperature

A common and simple problem is to compute the output noise power of an amplifier that has a conjugate-matched terminations connected to its input and output. Usually, one has knowledge of the amplifier's gain G_a , noise factor F and source noise temperature T_0 . Using (10-30), one can write the output noise power as

$$P_{no} = F G_a P_{ni} = F G_a k T_0 B. \quad (10-34)$$

Suppose that we are given a noise source, at temperature T_0 , connected to an amplifier (or two-port device) having an effective noise temperature of T_e . The noise power output of the amplifier is given by (10-34) **and** the first equation of (10-28). Equating these expressions, we get

$$P_{no} = G_a k (T_0 + T_e) B = F G_a k T_0 B, \quad (10-35)$$

and this result can be solved for

$$F = \frac{T_0 + T_e}{T_0} = 1 + \frac{T_e}{T_0}. \quad (10-36)$$

Alternatively, this result can be solved for

$$T_e = T_0 (F - 1). \quad (10-37)$$

As discussed previously, noise factor F depends on input noise power; hence, it is not surprising that F , given by (10-36), depends on input noise temperature T_0 . Hence, referenced to a standard noise source at temperature $T_0 = 290^\circ$ Kelvin, noise factor F can be expressed in terms of equivalent noise temperature T_e (*i.e.*, (10-36)), and vice versa (*i.e.*, (10-37)).

Example 10-8: To continue the 2N6680 example given earlier, assume that Agilent used a standard noise source (*i.e.*, one at $T_0 = 290^\circ$ Kelvin) when they measured the 1.6 dB noise figure of their device. The noise temperature of an optimally designed (for minimum noise figure) 2N6680-based amplifier would be on the order of $T_e = 290(10^{0.16} - 1) = 129.2^\circ$ Kelvin.

Noise Factor of a Purely Resistive Attenuator

Suppose we have a two port network comprised only of resistors. For example, both fixed and variable resistive *attenuators* are available commercially from many vendors. In some applications, a “long” run of coax cable can contribute significant losses; in many of these cases, the coax can be *modeled* as a purely resistive attenuator (coax loss is approximately constant over small fractional bandwidths). Let G_a , $0 < G_a < 1$, denote the gain of the resistive attenuator. Also, for purposes of determining attenuator noise factor, we make the assumption that the resistive attenuator is at the same absolute temperature $T_0 = 290^\circ$ Kelvin as the resistive noise source connected to its input (unless specified otherwise, noise factor/figure is *always* specified relative to a standard noise source, a resistor at $T_0 = 290^\circ$ Kelvin). Finally, we assume that the attenuator is impedance matched on its input and output ports.

Under the conditions outlined in the previous paragraph, a resistive attenuator has a noise factor F different than unity. The reason for this is that the attenuator’s resistive components contribute noise, and $(\text{SNR})_{\text{OUT}} \neq (\text{SNR})_{\text{IN}}$. As we now show, the noise factor of the attenuator can be taken as $F = G_a^{-1}$. To see this, we model the noise source-attenuator combination in two equivalent ways. First, we model the combination as a single resistive noise source at T_0 degrees Kelvin. For this interpretation, the attenuator output noise power is

$$P_{\text{na}} = kT_0B \quad (10-38)$$

watts. But on the other hand, the attenuator can be viewed as a noisy device, characterized by a less-than-unity gain G_a and an equivalent input temperature of T_e degrees Kelvin. Since the attenuator is connected to a noise source at T_0 degrees Kelvin, the first of (10-28) leads to

$$P_{na} = G_a k (T_0 + T_e) B. \quad (10-39)$$

Equations (10-38) and (10-39) should produce the same results; when they are equated, we get the formula

$$T_e = (G_a^{-1} - 1) T_0. \quad (10-40)$$

Now, substitute (10-40) into (10-36) to obtain

$$F = 1 + \frac{(G_a^{-1} - 1) T_0}{T_0} = G_a^{-1} \quad (10-41)$$

as the attenuator noise factor F . Finally, use (10-41) to determine

$$NF = 10 \text{Log}(F) = 10 \text{Log}(1/G_a) = -10 \text{Log}(G_a) \text{ dB}, \quad (10-42)$$

a positive result (since $G_a < 1$ for an attenuator). So, the noise figure (NF) of the attenuator/lossy coax is just its loss in dB.

Overall Noise Figure of Cascaded Networks

Most systems involve several stages connected in a cascade fashion. For example, a typical radio receiving system consists of a combination of antenna, feed line (*i.e.*, coax), *RF* amplifier, down converter, *IF* amplifier followed by other stages. In order to perform a noise analysis of such systems, we need to know how to compute the noise factor of a cascade of

stages given the noise factor and gain of the individual stages. Typically, the overall noise factor F is calculated for a bandwidth B that is the bandwidth of the overall system, rather than that of individual stages.

Figure 10-9 depicts two cascaded-connected stages with associated gains, effective noise temperatures and noise figures. A standard noise source (a resistor at temperature T_0) is connected to the input side. The noise power output delivered to the load is

$$\begin{aligned}
 P_{\text{no}} &= \underbrace{G_{a_1} G_{a_2} k T_0 B}_{\text{due to source } T_0} + \underbrace{G_{a_1} G_{a_2} k T_{e_1} B}_{\text{due to first two-port}} + \underbrace{G_{a_2} k T_{e_2} B}_{\text{due to second two-port}} \\
 &= G_{a_1} G_{a_2} \underbrace{k T_0 B}_{\text{From Input}} + G_{a_1} G_{a_2} \underbrace{k \left(T_{e_1} + \frac{T_{e_2}}{G_{a_1}} \right) B}_{\substack{\text{Internally Generated} \\ \text{(Referenced to Input of Cascade)}}} \quad (10-43) \\
 &= G_{a_1} G_{a_2} k \left[T_0 + \left\{ T_{e_1} + \frac{T_{e_2}}{G_{a_1}} \right\} \right] B
 \end{aligned}$$

Let $T_{e_{1,2}}$ denote the noise temperature of the cascaded network. Then, comparison of (10-43) to the first equation of (10-28) leads to the conclusion

$$T_{e_{1,2}} = T_{e_1} + \frac{T_{e_2}}{G_{a_1}}. \quad (10-44)$$

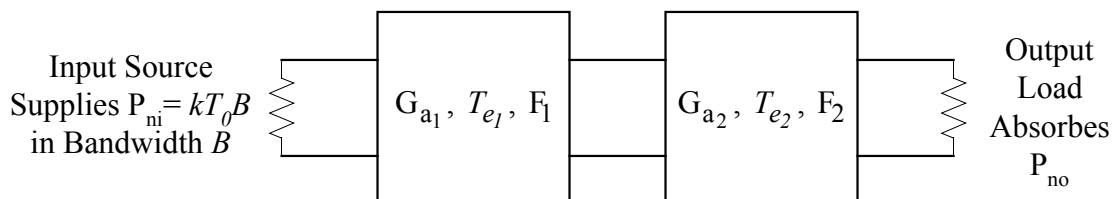

Figure 10-9: A cascade of two-port devices.

$T_{e_{1,2}}$ accounts for the noise introduced by both two-ports acting together. It is the overall noise temperature of the cascaded two-port.

This process can be extended to the case of n such cascaded two-port networks. Following the approach just outlined, one can easily find that n cascaded networks has an overall noise temperature of

$$T_{e_{1,n}} = T_{e_1} + \frac{T_{e_2}}{G_{a_1}} + \frac{T_{e_3}}{G_{a_1}G_{a_2}} + \dots + \frac{T_{e_n}}{G_{a_1}G_{a_2}\dots G_{a_{(n-1)}}}, \quad (10-45)$$

where T_{e_k} is the noise temperature of the k^{th} network in the chain.

The overall noise factor of n cascaded networks can be expressed in terms of the individual noise factors. First, use (10-37) to write

$$T_{e_k} = T_0(F_k - 1), \quad (10-46)$$

where F_k is the noise factor of the k^{th} network. Now, substitute (10-46) into (10-45) to obtain

$$T_{e_{1,n}} = T_0(F_1 - 1) + \frac{T_0(F_2 - 1)}{G_{a_1}} + \frac{T_0(F_3 - 1)}{G_{a_1}G_{a_2}} + \dots + \frac{T_0(F_n - 1)}{G_{a_1}G_{a_2}\dots G_{a_{(n-1)}}}, \quad (10-47)$$

for the overall noise temperature of the cascaded network. Finally, use this last expression for the two-port equivalent noise temperature in (10-36) to obtain

$$F_{1,n} = F_1 + \frac{F_2 - 1}{G_{a_1}} + \frac{F_3 - 1}{G_{a_1}G_{a_2}} + \dots + \frac{F_n - 1}{G_{a_1}G_{a_2}\dots G_{a_{(n-1)}}}, \quad (10-48)$$

a result known as *Friss' formula*.

Equation (10-48) tells a very important story. Basically, inspection of (10-48) reveals that the *first* two-port in a chain has the predominant effect on the overall noise factor, unless G_{a_1} is very small or F_2 is very large. In practical system design, one should pay particular attention to the noise performance of the *first* stage in a chain since it will, most likely, establish the overall noise properties of the chain. For example, in the design of VHF, UHF and microwave receiving systems, one usually optimizes the noise performance of the receiver's *RF* amplifier (which is the first stage); latter stages have little influence on the receiver's noise performance. Often, an external, low noise, *RF* amplifier will be placed at the antenna to avoid feed line loss (which can be several dB) from decreasing the effective value of G_{a_1} .

Example 10-9: Consider a VHF receiver and antenna that are interconnected with coax cable having a loss of 1.5dB (for example, 100ft of RG213 coax at 50Mhz). Suppose the receiver's *RF* amplifier (the receiver's first stage) has a noise figure of $NF_2 \equiv 7\text{dB}$ and a gain of 20dB. The active FET mixer (the receiver's second stage) has a noise figure and a conversion gain of 8dB. The mixer is followed by an *IF* amplifier that is based on a Motorola MC1590G integrated circuit; the *IF* amplifier has a gain of 60dB and a noise figure of $NF_4 \equiv 6\text{dB}$.

a) Find the noise figure and noise temperature of the coax and receiver combination. The "stages" are arranged in the order given below.

1) Coax: Pwr Gain = -1.5dB so that $G_{a_1} = 10^{-1.5/10} = .7080$

$$F_1 = 1/G_{a_1} = 1.413$$

2) *RF* Amp: Pwr Gain = 20 dB so that $G_{a_2} = 10^{20/10} = 100$

$$NF_2 = 7\text{dB so that } F_2 = 10^{7/10} = 5.012$$

3) Mixer: Pwr Gain = 8dB so that $G_{a_3} = 10^{8/10} = 6.310$

$$NF_3 = 8\text{dB so that } F_3 = 10^{8/10} = 6.310$$

4) *IF* Amp: Pwr Gain = 60dB so that $G_{a_4} = 10^{60/10} = 10^6$

$$NF_4 = 6\text{dB so that } F_4 = 10^{6/10} = 3.981$$

Substitute the above data into Friss' formula (10-48) to obtain

$$F = 1.413 + \frac{5.012 - 1}{.7080} + \frac{6.310 - 1}{.7080 \times 100} + \frac{3.981 - 1}{.7080 \times 100 \times 6.310} = 7.16, \quad (10-49)$$

or $NF = 8.55\text{dB}$. Use Equation (10-37) to calculate the overall noise temperature as

$$T_e = T_0(F - 1) = 290(7.16 - 1) = 1786^\circ \text{Kelvin}. \quad (10-50)$$

At a value of 7.080, the first two terms of (10-49) dominate the final answer; that is, the coax loss and RF amplifier come close to setting the overall system noise factor. Also, note that the 1.5 dB coax loss (and the resulting coax noise factor) has a significant adverse affect on overall system noise factor. The adverse affect of coax loss can be minimized/eliminated by placing the RF amplifier at the antenna feed point, ahead of the coax. This situation is analyzed in part b).

b) Consider changing the receiving system so that the RF amplifier is at the antenna end of the coax, mounted in a small aluminum box to protect it from the weather (so there is no feed line loss between the antenna and the RF amplifier). At the receiver end, the coax is impedance matched directly to the mixer input. That is, interchange 1) and 2) in the above lineup. Use the same values for component noise figures and gains, and repeat part a). With this configuration, the overall system noise figure is

$$F = 5.01 + \frac{1.41 - 1}{10^2} + \frac{6.310 - 1}{.7080 \times 100} + \frac{3.981 - 1}{.7080 \times 100 \times 6.310} = 5.10, \quad (10-51)$$

or $NF = 7.07\text{ dB}$. Note that this overall NF is very close to the NF ($= 7\text{dB}$) of the RF amplifier alone!! The first stage (*i.e.*, the RF amplifier) set the overall system NF !! The new system noise temperature is

$$T_e = 290(4.10) = 1189^\circ \text{Kelvin} \quad (10-52)$$

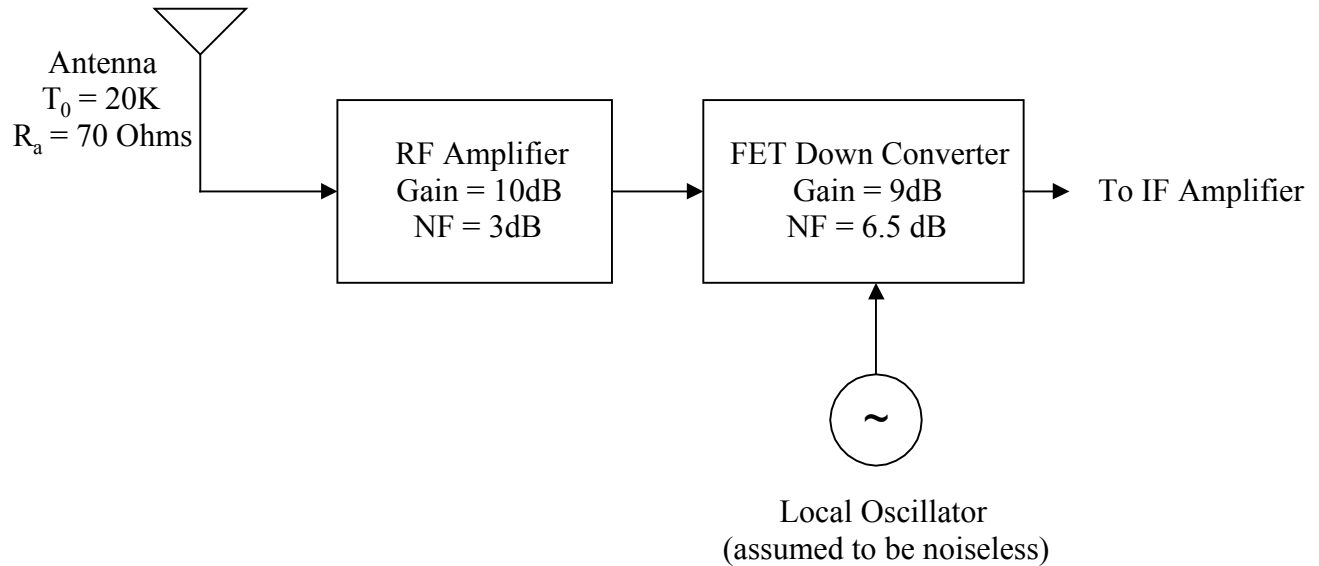

Figure 10-10: Receiver front-end.

This simple “swap” virtually eliminated the adverse affects of coax loss on system noise figure.

Example 10-10: Consider the receiver “front end” depicted by Figure 10-10. The radiation resistance of the antenna is 70 ohms. Ambient (atmospheric) noise is responsible for the antenna noise; the antenna noise temperature is 20° Kelvin. The noise figures of the *RF* and mixer stages are given in dB. The local oscillator (*LO*) is assumed to generate no noise (this is not a good assumption in all practical cases; *LO* noise is significant in most applications). Find the noise temperature and noise figure of the receiver front end. For the *RF* stage, the noise factor $F_1 = 2$, and gain $G_{a_1} = 10$. For the mixer, $F_2 = 4.47$, and conversion gain $G_{a_2} = 7.94$. The noise temperatures of the *RF* and mixer stages can be computed by using (10-37); the results are $T_{e_1} = 290^\circ\text{Kelvin}$ and $T_{e_2} = 1006^\circ\text{Kelvin}$. Excluding the antenna, the effective input temperature of the receiver is found to be

$$T_R = T_{e_1} + T_{e_2} / G_{a_1} = 391^\circ\text{Kelvin} \quad (10-53)$$

by using (10-44). Finally, the front-end noise factor is $F = 2.35$ (which equates to a noise figure of $\text{NF} = 3.7\text{dB}$), a result computed by using (10-48).