

CPE 426/526

Chapter 4 - Basic VHDL Modeling Techniques

Dr. Rhonda Kay Gaede

UAH

UAH

Chapter 4

CPE 426/526

4.1 Modeling Delay in VHDL - Propagation Delay

- Signals have a propagation delay of at least _____
- Variables change _____

4.1 Modeling Delay in VHDL - Delta delay versus real time delay

```
entity STATEMENTS is
  port(X,Y,Z: in INTEGER; -- Note that entity ports are
        B: out INTEGER); -- always signals.
end STATEMENTS;

architecture PROP_DELAY of STATEMENTS is
  signal AS: INTEGER;
begin
  process (X,Y,Z)
  begin
    AS <= X*Y after 2 ns; --Statement (1)
    B <= AS+Z after 2 ns; --Statement (2)
  end process;
end PROP_DELAY;

architecture DELTA_DELAY of STATEMENTS is
  signal AS: INTEGER;
begin
  process (X,Y,Z)
  begin
    AS <= X*Y; --Statement (1)
    B <= AS+Z; --Statement (2)
  end process;
end DELTA_DELAY;
```

Page 3 of 30

4.1 Modeling Delay in VHDL - Variables don't have propagation delay

```
architecture INSTANTANEOUS of STATEMENTS
  is
begin
  process(X,Y,Z)
    variable AV,BV: INTEGER;
  begin
    AV := X*Y; --Statement (3)
    BV := AV+Z; --Statement (4)
    B <= BV;
  end process;
end INSTANTANEOUS;
```

Page 4 of 30

4.1 Modeling Delay in VHDL - Delay and Concurrency

- Since logic signals flow in parallel, VHDL models of logic circuits must include provision for _____ of execution.
- All processes execute in parallel - a concurrent statement is a process with an _____ sensitivity list.
- Look at the simulation of the previous example

4.1 Modeling Delay in VHDL - Simulation of Time Delay

```
entity BUFF is
  port(X: in BIT; Z: out BIT);
end BUFF;
```

```
architecture ONE of BUFF is
begin
  process(X)
    variable Y1: BIT;
  begin
    Y1 := X;
    Z <= Y1 after 1 ns;
  end process;
end ONE;
```

```
architecture TWO of BUFF is
  signal Y2: BIT;
begin
  Y2 <= X ;
  Z <= Y2 ;
end TWO;
```

```
architecture THREE of BUFF is
  signal Y3: BIT;
begin
  Y3 <= X;
  Z <= Y3 after 1 ns;
end THREE;
```

```
architecture FOUR of BUFF is
  signal Y4: BIT;
begin
  Y4 <= X after 1 ns;
  Z <= Y4 after 1 ns;
end FOUR;
```

4.1 Modeling Delay in VHDL - Inertial and Transport Delay

Z <= I after 10 ns;
Z <= transport I after 1 ns;

- **Scheduling Rules**

	Transport	Inertial
New before existing	Overwrite existing	Overwrite existing
New after existing	Append new	If $v_{\text{new}} = v_{\text{existing}}$ append new
		Elsif $t_{\text{new}} - t_{\text{existing}} >$ reject append new
		Else overwrite existing

- For stimuli, use transport or one statement with commas.
Z <= '1' after 50 ns;
Z <= '0' after 100 ns;

4.2 The VHDL Scheduling Algorithm

- This selection details how delay is implemented.
- We need to understand three concepts
 - Driver
 - Transaction
 - Waveform
- Once a transaction becomes current and simulation time then advances, that transaction is deleted.

Simulation Example

Signal Drivers

```

entity simulation_example is
end simulation_example;

architecture test1 of simulation_example is
signal A,B: bit;
begin
  P1: process(B)
  begin
    A <= '1';
    A <= transport '0' after 5 ns;
  end process P1;

  P2: process(A)
  begin
    if A = '1' then B <= not B after 10 ns; end if;
  end process P2;
end test1;
    
```

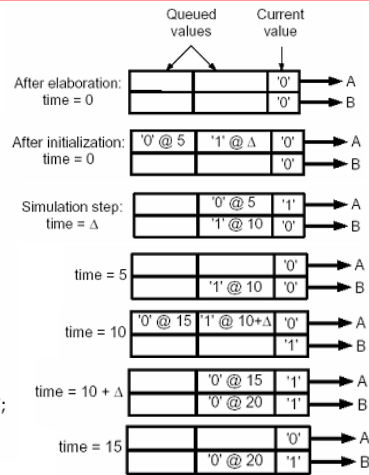

Another Simulation Example

```

entity prob is
  port (D : inout bit);
end prob;

architecture PROB of PROB is
signal A, B, C, E, F : bit;
begin
  P1: process (A, C)
  begin
    B <= A after 3 ns;
    E <= C after 5 ns;
  end process P1;
  C1: C <= A after 10 ns;
  P2: process (C, E)
  begin
    F <= C and E after 4 ns;
  end process P2;
  C2: D <= A or B or C or F after 1 ns;
end PROB;
    
```

Assume that A changes to '1' at 5 ns.

4.4 Logic Primitives

```
entity AND2 is
  generic(DEL: TIME);
  port(I1,I2: in BIT; O: out
        BIT);
end AND2;
architecture DF of AND2 is
begin
  O <= I1 and I2 after DEL;
end DF;
```

```
entity BUF is
  generic(DATA_DEL,Z_DEL:
        TIME);
  port(I,EN: in BIT; O: out
        BIT);
end BUF;
architecture ALG of BUF is
begin
  process(I,EN)
  begin
    if EN = '1' then
      O <= I after DATA_DEL;
    else
      O <= '1' after Z_DEL;
    end if;
  end process;
end ALG;
```

4.4 Logic Primitives

```
entity FULL_ADDER is
  generic(SUM_DEL,CARRY_DEL:TIME);
  port(A,B,CI: in BIT; SUM,COUT: out BIT);
end FULL_ADDER;

architecture DF of FULL_ADDER is
begin
  SUM <= A xor B xor CI after SUM_DEL;
  COUT <= (A and B) or (A and CI) or (B and CI)
         after CARRY_DEL;
end DF;
```

4.4 Logic Primitives

```
entity FOUR_TO_1_MUX is
  generic(DEL: TIME);
  port(IN0,IN1,IN2,IN3: in BIT_VECTOR(3
    downto 0);
        SEL: in BIT_VECTOR(1 downto 0);
        O: out BIT_VECTOR(3 downto 0));
end FOUR_TO_1_MUX;

architecture DF of FOUR_TO_1_MUX is
begin
  O <= IN0 after DEL when SEL = "00" else
        IN1 after DEL when SEL = "01" else
        IN2 after DEL when SEL = "10" else
        IN3 after DEL;
end DF;
```

4.4 Logic Primitives

```
entity TWO_TO_4_DEC is
  generic(DEL: TIME);
  port(I: in BIT_VECTOR(1 downto 0);
        O: out BIT_VECTOR(3 downto 0));
end TWO_TO_4_DEC;

architecture ALG of TWO_TO_4_DEC is
begin
  process(I)
  begin
    case I is
      when "00" => O<= "0001" after DEL;
      when "01" => O<= "0010" after DEL;
      when "10" => O<= "0100" after DEL;
      when "11" => O<= "1000" after DEL;
    end case;
  end process;
end ALG;
```

4.4 Logic Primitives

```

entity FOUR_TO_2_ENC is
  generic(DEL: TIME);
  port(I: in BIT_VECTOR(3 downto 0);
        O: out BIT_VECTOR(1 downto 0));
end FOUR_TO_2_ENC;

architecture DF of FOUR_TO_2_ENC is
begin
  O <= "00" after DEL when I(0) = '1' else
        "01" after DEL when I(1) = '1' else
        "10" after DEL when I(2) = '1' else
        "11" after DEL;
end DF;

```

4.4 Logic Primitives

```

entity SHIFTER is
  generic(DEL: TIME);
  port(DATA_IN: in BIT_VECTOR(3 downto 0);
        SR,SL: in BIT; IL,IR: in BIT;
        DATA_OUT: out BIT_VECTOR(3 downto 0));
end SHIFTER;
architecture ALG of SHIFTER is
begin
  process(SR,SL,DATA_IN,IL,IR)
    variable CON: BIT_VECTOR(0 to 1);
  begin
    CON := SR&SL;
    case CON is
      when "00" => DATA_OUT <= DATA_IN after DEL;
      when "01" => DATA_OUT <= DATA_IN(2 downto 0) & IL
                    after DEL;
      when "10" => DATA_OUT <= IR & DATA_IN(3 downto 1)
                    after DEL;
      when "11" => DATA_OUT <= DATA_IN after DEL;
    end case;
  end process;
end ALG;

```

4.4 Logic Primitives

```

use work.PRIMS.all;
entity ALU is
  generic(DEL: TIME);
  port(A,B: in BIT_VECTOR(3 downto 0); CI: in BIT;
        FSEL: in BIT_VECTOR(1 downto 0);
        F: out BIT_VECTOR(3 downto 0); COUT: out BIT);
end ALU;
architecture ALG of ALU is
begin
  process(A,B,CI,FSEL)
    variable FV: BIT_VECTOR(3 downto 0);
    variable COUTV: BIT;
  begin
    case FSEL is
      when "00" => F <= A after DEL;
      when "01" => F <= not(A) after DEL;
      when "10" => ADD(A,B,CI,FV,COUTV);
                    F <= FV after DEL;
                    COUT <= COUTV after DEL;
      when "11" => F <= A and B after DEL;
    end case;
  end process;
end ALG;

```

Page 17 of 30

4.4 Logic Primitives

```

package PRIMS is
  procedure ADD(A,B: in BIT_VECTOR; CIN: in BIT;
               SUM: out BIT_VECTOR; COUT: out BIT);
  function INC(X : BIT_VECTOR) return BIT_VECTOR;
  function DEC(X : BIT_VECTOR) return BIT_VECTOR;
  function INTVAL(VAL : BIT_VECTOR) return INTEGER;
end PRIMS;

package body PRIMS is
  procedure ADD(A,B: in BIT_VECTOR; CIN: in BIT;
               SUM: out BIT_VECTOR; COUT: out BIT) is
    variable SUMV,AV,BV: BIT_VECTOR(A'LENGTH-1 downto 0);
    variable CARRY: BIT;
  begin
    AV := A;
    BV := B;
    CARRY := CIN;
    for I in 0 to SUMV'HIGH loop
      SUMV(I) := AV(I) xor BV(I) xor CARRY;
      CARRY := (AV(I) and BV(I)) or (AV(I) and CARRY)
              or (BV(I) and CARRY);
    end loop;
    COUT := CARRY;
    SUM := SUMV;
  end ADD;

```

Page 18 of 30

4.4 Logic Primitives

```

function INC(X : BIT_VECTOR) return BIT_VECTOR is
  variable XV: BIT_VECTOR(X'LENGTH-1 downto 0);
begin
  XV := X;
  for I in 0 to XV'HIGH loop
    if XV(I) = '0' then
      XV(I) := '1';
      exit;
    else XV(I) := '0';
    end if;
  end loop;
  return XV;
end INC;

function DEC(X : BIT_VECTOR) return BIT_VECTOR is
  variable XV: BIT_VECTOR(X'LENGTH-1 downto 0);
begin
  XV := X;
  for I in 0 to XV'HIGH loop
    if XV(I) = '1' then
      XV(I) := '0';
      exit;
    else XV(I) := '1';
    end if;
  end loop;
  return XV;
end DEC;

```

Page 19 of 30

4.4 Logic Primitives

```

function INTVAL ( VAL: BIT_VECTOR) return INTEGER is
  variable VALV: BIT_VECTOR(VAL'LENGTH - 1 downto 0);
  variable SUM: INTEGER := 0;
begin
  VALV := VAL;
  for N in VALV'LOW to VALV'HIGH loop
    if VALV(N) = '1' then
      SUM := SUM + (2**N);
    end if;
  end loop;
  return SUM;
end INTVAL;
end PRIMS;

```

Page 20 of 30

4.4 Logic Primitives

FIGURE 3-10:
PLA with Three
Inputs, Five Product
Terms, and Four
Outputs (Logic
Level)

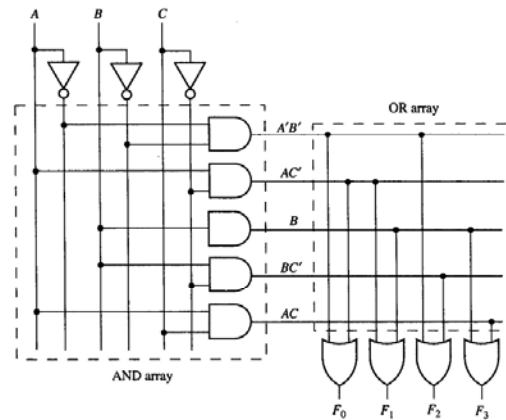

4.4 Logic Primitives

```

entity PLA is
  generic(AND_DEL,OR_DEL: TIME);
  port(X: in BIT_VECTOR(1 to 3); Z: out BIT_VECTOR(1 to 4));
end PLA;
architecture CONNECTION_MATRIX of PLA is
  signal R: BIT_VECTOR(1 to 4);
begin
  AND_PLANE: process(X)
    variable RV: BIT_VECTOR(1 to 4);
    type AND_ARRAY is array( 1 to 4, 1 to 3, 1 to 2 ) of BIT;
    variable AND_PL: AND_ARRAY :=
      ((('0','1'),('0','0'),('0','0')), (('0','0'),('1','0'),('1','0')),
      (('1','0'),('1','0'),('0','1')), (('1','0'),('0','1'),('1','0')));
  begin
    for I in 1 to 4 loop
      RV(I) := '0';
      for J in 1 to 3 loop
        assert not(AND_PL(I,J,1) = '1' and AND_PL(I,J,2) = '1')
          report "Error in AND plane wiring";
        if AND_PL(I,J,1) = '1' then
          RV(I) := RV(I) or X(J);
        end if;
        if AND_PL(I,J,2) = '1' then RV(I) := RV(I) or not X(J);
        end if;
      end loop;
      R(I) <= not RV(I) after AND_DEL;
    end loop;
  end process AND_PLANE;
end architecture CONNECTION_MATRIX;

```

4.4 Logic Primitives

```

OR_PLANE: process(R)
  variable ZV: BIT_VECTOR(1 to 4);
  type OR_ARRAY is array(1 to 4,1 to 4) of BIT;
  variable OR_PLANE: OR_ARRAY :=
    (('1','0','0','0'),('1','0','1','0'),
     ('0','1','0','0'),('0','0','1','1'));
  begin
    for I in 1 to 4 loop
      ZV(I) := '0';
      for J in 1 to 4 loop
        if OR_PLANE(I,J) = '1' then ZV(I) := ZV(I) or R(J);
        end if;
      end loop;
      Z(I) <= ZV(I) after OR_DEL;
    end loop;
  end process OR_PLANE;
end CONNECTION_MATRIX;

```

Page 23 of 30

4.4 Logic Primitives

```

entity JKFF is
  generic(SRDEL,CLKDEL: TIME);
  port(S,R,J,K,CLK: in BIT; Q,QN: inout BIT);
end JKFF;

architecture ALG of JKFF is
begin
  process(CLK,S,R)
  begin
    if S = '1' and R = '0' then
      Q <= '1' after SRDEL; QN <= '0' after SRDEL;
    elsif S = '0' and R = '1' then
      Q <= '0' after SRDEL; QN <= '1' after SRDEL;
    elsif CLK'EVENT and CLK = '1' and S='0' and R='0' then
      if J = '1' and K = '0' then
        Q <= '1' after CLKDEL; QN <= '0' after CLKDEL;
      elsif J = '0' and K = '1' then
        Q <= '0' after CLKDEL; QN <= '1' after CLKDEL;
      elsif J = '1' and K = '1' then
        Q <= not Q after CLKDEL; QN <= not QN after CLKDEL;
      end if;
    end if;
  end process;
end ALG;

```

Page 24 of 30

4.4 Logic Primitives

```
entity REG is
  generic(DEL: TIME);
  port(RESET,LOAD,CLK: in BIT;
        DATA_IN: in BIT_VECTOR(3 downto 0);
        Q: inout BIT_VECTOR(3 downto 0));
end REG;

architecture DF of REG is
begin
  REG: block(not CLK'STABLE and CLK = '1')
  begin
    Q <= guarded "0000" after DEL when RESET = '1' else
        DATA_IN after DEL when LOAD = '1' else
        Q;
  end block REG;
end DF;
```

4.4 Logic Primitives

```
entity LATCH is
  generic(LATCH_DEL:TIME);
  port(D: in BIT_VECTOR(7 downto 0);
        CLK: in BIT; LOUT: out BIT_VECTOR(7 downto 0));
end LATCH;

architecture DFLOW of LATCH is
begin
  LATCH: block(CLK = '1')
  begin
    LOUT <= guarded D after LATCH_DEL;
  end block LATCH;
end DFLOW;
```

4.4 Logic Primitives

```

entity SHIFTRREG is
  generic(DEL: TIME);
  port(DATA_IN: in BIT_VECTOR(3 downto 0);
        CLK,LOAD,SR,SL: in BIT; IL,IR: in BIT;
        Q: inout BIT_VECTOR(3 downto 0));
end SHIFTRREG;

architecture DF of SHIFTRREG is
begin
  SH:block(not CLK'STABLE and CLK ='1')
  begin
    Q <= guarded DATA_IN after DEL when LOAD= '1' else
    Q(2 downto 0) & IL after DEL when SL='1' and SR='0' else
    IR & Q(3 downto 1) after DEL when SL='0' and SR='1' else
    Q;
  end block SH;
end DF;

```

Page 27 of 30

4.4 Logic Primitives

```

entity COUNTER is
  generic(DEL:TIME);
  port(RESET,LOAD,COUNT,UP,CLK: in BIT;
        DATA_IN: in BIT_VECTOR(3 downto 0);
        CNT: inout BIT_VECTOR(3 downto 0));
end COUNTER;

use work.PRIMS.all;
architecture ALG of COUNTER is
begin
  process(CLK)
  begin
    if CLK = '1' then
      if RESET = '1' then
        CNT <= "0000" after DEL;
      elsif LOAD = '1' then
        CNT <= DATA_IN after DEL;
      elsif COUNT = '1' then
        if UP = '1' then
          CNT <= INC(CNT) after DEL;
        else
          CNT <= DEC(CNT) after DEL;
        end if;
      end if;
    end if;
  end process;
end ALG;

```

Page 28 of 30

4.4 Logic Primitives

```

use work.PRIMS.all;
entity RAM is
  generic (RDEL,DISDEL: TIME);
  port (DATA: inout BIT_VECTOR(3 downto 0);
        ADDRESS: in BIT_VECTOR(4 downto 0);
        RD,WR,NCS: in BIT);
end RAM;

architecture SIMPLE of RAM is
  type MEMORY is array(0 to 31) of BIT_VECTOR(3 downto 0);
begin
  process(RD,WR,NCS,ADDRESS,DATA)
    variable MEM: MEMORY;
  begin
    if NCS='0' then
      if RD='1' then
        DATA <= MEM(INTVAL(ADDRESS)) after RDEL;
      elsif WR='1' then
        MEM(INTVAL(ADDRESS)) := DATA;
      end if;
    else
      DATA <= "1111" after DISDEL;
    end if;
  end process;
end SIMPLE;

```

Page 29 of 30

4.4 Text I/O Test Bench

```

use STD.TEXTIO.all;
architecture ONES_CNT1 of TEST_BENCH is
  signal PLAY: BIT;
  signal A: BIT_VECTOR(2 downto 0);
  signal C: BIT_VECTOR(1 downto 0);
  component ONES_CNTA
    port (A: in BIT_VECTOR(2 downto 0); C: out BIT_VECTOR(1 downto 0));
  end component;
  for L1: ONES_CNTA use entity ONES_CNT(ALGORITHMIC);
begin
  L1: ONES_CNTA port map(A, C);
  process
    variable VLINE: LINE;
    variable V1: BIT_VECTOR(2 downto 0); variable V2: BIT_VECTOR(1 downto 0);
    file INVECT: TEXT is "TVECT.TEXT";
  begin
    PLAY<= '0', '1' after 3 ns;
    wait on PLAY until PLAY = '1';
    while not(ENDFILE(INVECT)) loop
      READLINE(INVECT, VLINE);
      READ(VLINE, V1); READ(VLINE, V2);
      A<= V1;
      wait for 1 ns;
      assert (V2 = C) report "WARNING: C is NOT equal to (V2 or C)" severity WARNING;
    end loop;
  end process;
end ONES_CNT1;

```

Page 30 of 30