

The University of Alabama in Huntsville
Electrical & Computer Engineering Department
CPE 426 01
Final Exam Solution
Spring 2002

Name: _____

1. (5 points) What kind of hardware element will be inferred by a synthesis tool from the following model? Answer: a latch, since the behavior is level sensitive

```
library ieee;
use ieee.std_logic_1164.all;

entity WIDGET is
  Port (A, B : in SIGNED (0 to 2);
        CLK, RESET : in std_logic;
        Z : out SIGNED(0 to 2));
end WIDGET;

architecture EXAMPLE of WIDGET is
begin
  process (CLK, RESET)
  begin
    if (RESET = '1' then
      Z <= '0';
    elsif (CLK = '1') then
      Z <= A nor B;
    end if;
  end process;
end EXAMPLE;
```

2. (9 points) Draw the transistor-level diagram of a CMOS three-input NAND gate.

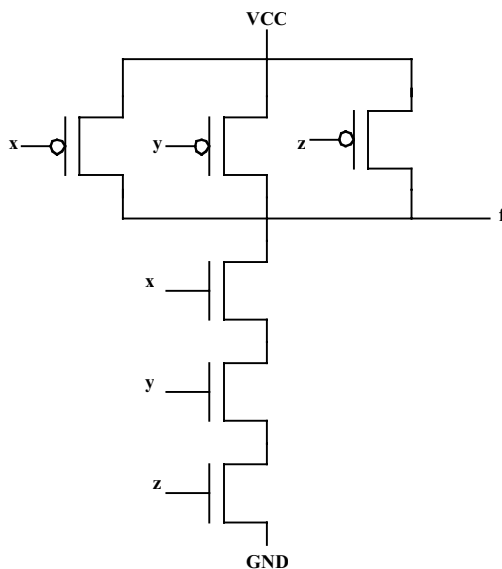

3. (12 points) Modify the following VHDL model by adding a parameter that sets the number of flip-flops in the counter. Also, add an input which is loaded with an asynchronous load input signal which is active low.

```
library ieee;
use ieee.std_logic_1164.all;
use ieee.std_logic_unsigned.all;

entity UPCOUNT is
    generic (N : integer);
    port ( CLOCK, RESETN, E : in std_logic;
          LD : in std_logic;
          LD_INPUT : in std_logic_vector (N-1 downto 0);
          Q : out std_logic_vector (N-1 downto 0));
end UPCOUNT;

architecture BEHAVIOR of UPCOUNT is
    signal COUNT : std_logic_vector (N-1 downto 0);
begin
    process (CLOCK, RESETN, LD)
    begin
        if RESETN = '0' then
            COUNT <= (OTHERS => '0');
            if (LD = '0') then
                COUNT <= LD_INPUT;
            elsif (CLOCK' event and CLOCK = '1') then
                if E = '1' then
                    COUNT <= COUNT + 1;
                else
                    COUNT <= COUNT;
                end if;
            end if;
        end process
        Q <= COUNT;
    end BEHAVIOR;
```

Consider the following VHDL code:

```
-----  
-- Entity declaration  
-----  
  
entity SCHED2 is  
  port (A, B, C, D, E, F: in INTEGER;  
        CLK : in BIT;  
        W, X, Y: out INTEGER);  
end SCHED2;  
  
-----  
-- Architecture declaration  
-----  
  
architecture HIGH_LEVEL of SCHED2 is  
  signal Z: INTEGER;  
begin  
  X <= (A - B) * C * D;  
  Y <= (A * B) + (E + F)/D;  
  W <= (C + F) * B  
end HIGH_LEVEL;
```

4. (18 points) The following tasks refer to the VHDL code above. Assume that there are no hardware constraints.

a. (6 points) Draw a data flow graph.

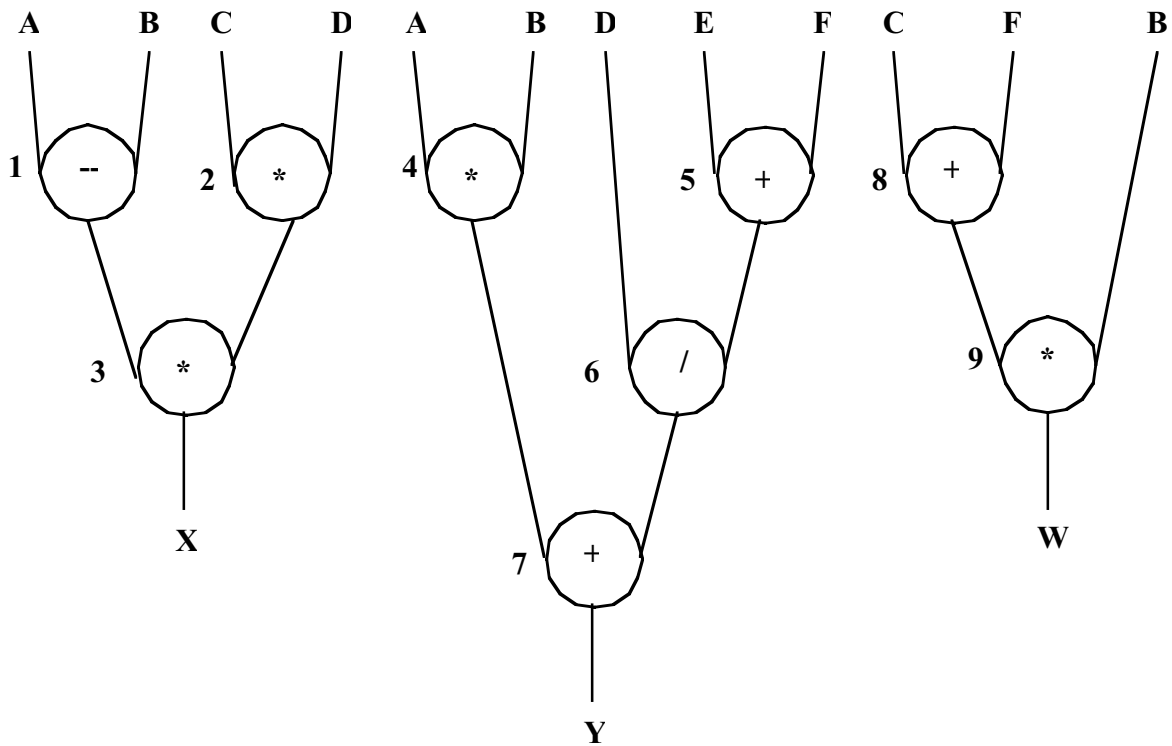

b. (6 points) Derive an ASAP schedule.

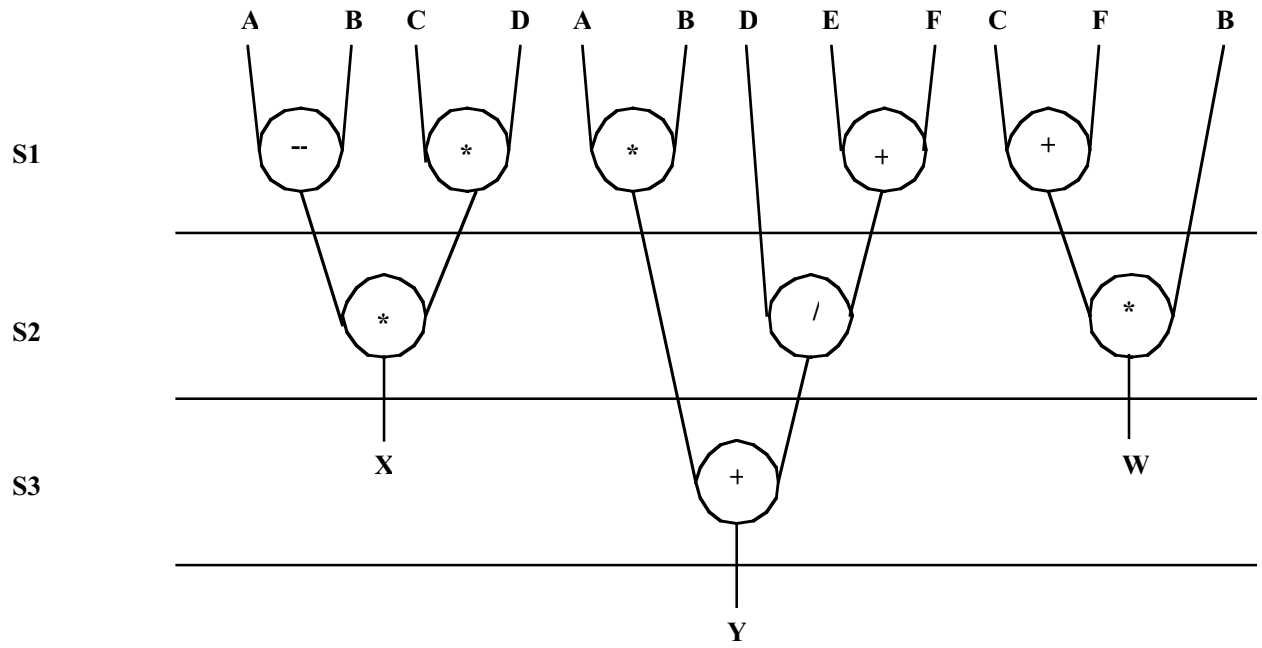

c. (6 points) Derive an ALAP schedule.

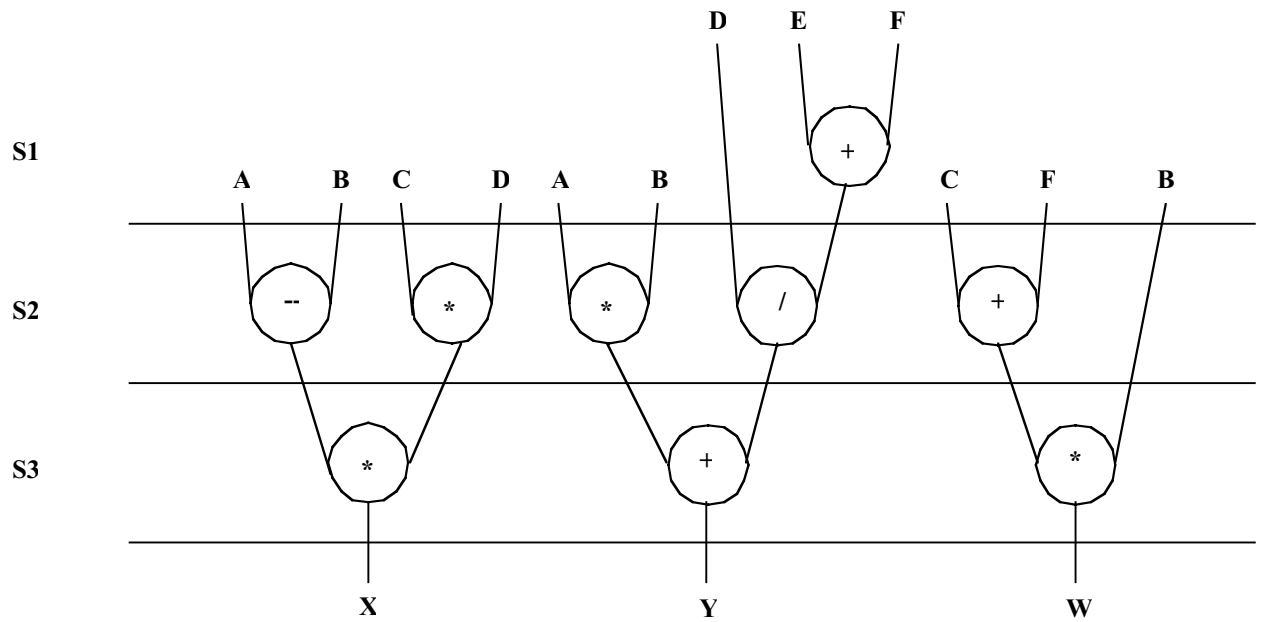

5. (10 points) Derive a schedule using the freedom-directed method for the VHDL code above, using the following hardware constraint; all operations are done in an ALU module and there are two ALU modules available.

Operation	Earliest ASAP	Latest ALAP	Range
1	1	4	4
2	1	4	4
3	2	5	4
4	1	4	4
5	1	3	3
6	2	4	3
7	3	5	3
8	1	4	4
9	2	5	4

For two ALUs,

- Step 1 {1, 2, 4, 5, 8} schedule 5, 1
- Step 2 {2, 4, 8, 6} schedule 6, 2
- Step 3 {4, 8, 3} schedule 4, 8
- Step 4 {3, 7, 9} schedule 7, 3
- Step 5 {9} schedule 9

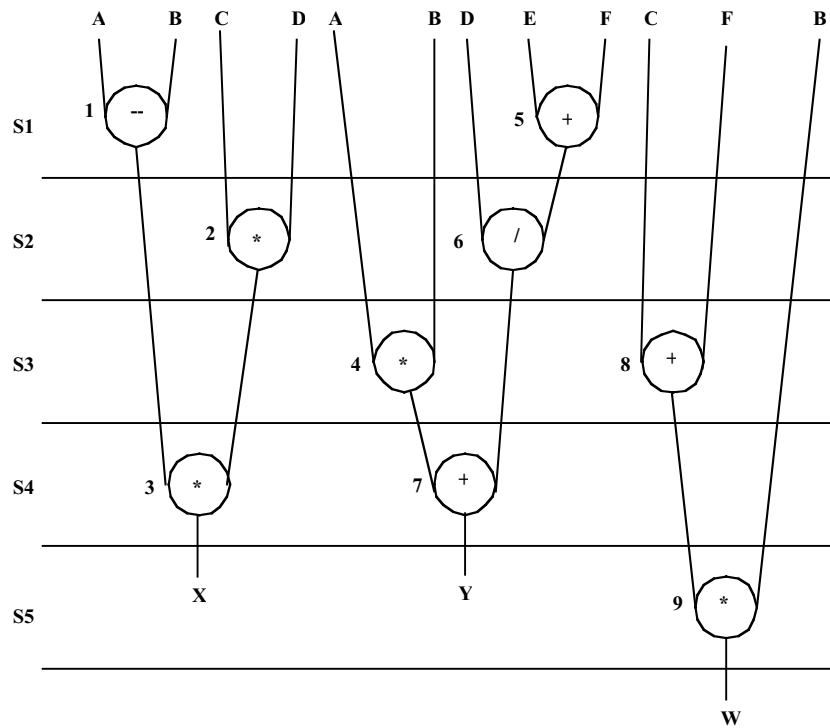

6. (4 points) List the four types of paths that must be considered when doing timing analysis of sequential circuits.

- _____ inputs to inputs of storage elements_____
- _____ inputs to outputs_____
- _____ outputs of storage elements to inputs of storage element_____
- _____ outputs of storage elements to outputs_____

7. (10 points) For the data lifetime chart shown, use the left edge algorithm to obtain an efficient register allocation.

	A	B	C	D	E	F	G	H	I	J
S1			X	X						X
S2			X							X
S3			X				X			X
S4	X						X			X
S5	X						X			
S6	X	X				X				
S7	X	X				X				
S8		X				X		X		
S9		X						X	X	
S10		X			X			X	X	

	D	C	J	G	A	F	B	H	I	E
S1	X	X	X							
S2		X	X							
S3		X	X	X						
S4			X	X	X					
S5				X	X					
S6					X	X	X			
S7					X	X	X			
S8						X	X	X		
S9							X	X	X	
S10							X	X	X	X

	R1	R2	R3	R4
S1	D	C	J	
S2		C	J	
S3		C	J	G
S4			J	G
S5	A			G
S6	A	F	B	
S7	A	F	B	
S8		F	B	H
S9	I		B	H
S10	I	E	B	H

8. (2 points) A(n) _____ ASIC _____ is an integrated circuit produced for a specific application and produced in relatively small volumes.

9. (2 points) _____ VHDL _____ is an annoyingly strongly typed language.

10. (15 points) Create a VHDL entity named mux4to1 that represents a 4-to-1 multiplexer which has an architecture which uses a case statement to represent the functionality of the multiplexer. Create a second entity and its accompanying architecture that represents a 16-to-1 multiplexer by using at least four instances of the mux4to1 entity.

```

library ieee;
use ieee.std_logic_1164.all;

entity MUX4TO1 is
    port ( DATA_IN : in std_logic_vector (3 downto 0);
          SEL : in std_logic_vector (1 downto 0);
          DATA_OUT : out std_logic);
end MUX4TO1;

architecture CASEMUX of MUX4TO1 is
begin
    process (DATA_IN, SEL)
    begin
        case SEL is
            when "00"    => DATA_OUT <= DATA_IN(0);
            when "01"    => DATA_OUT <= DATA_IN(1);
            when "10"    => DATA_OUT <= DATA_IN(2);
            when "11"    => DATA_OUT <= DATA_IN(3);
            when others => DATA_OUT <= 'X';
        end case;
    end process;
end CASEMUX;

library ieee;
use ieee.std_logic_1164.all;
use work.all;

entity MUX16TO1 is
    port (DATA_IN : in std_logic_vector (15 downto 0);
          SEL : in std_logic_vector (3 downto 0);
          DATA_OUT : out std_logic);
end MUX16TO1;

architecture STRUCT of MUX16TO1 is
    component MUX4TO1C
        port (DATA_IN : in std_logic_vector (3 downto 0);
              SEL : in std_logic_vector (1 downto 0);
              DATA_OUT : out std_logic);
    end component;
    for all : MUX4TO1C use entity MUX4TO1(CASEMUX);
    signal INTERNAL : std_logic_vector (3 downto 0);
begin
    U1 : MUX4TO1C port map (DATA_IN(3 downto 0), SEL(1 downto 0), INTERNAL(3));
    U2 : MUX4TO1C port map (DATA_IN(7 downto 4), SEL(1 downto 0), INTERNAL(2));
    U3 : MUX4TO1C port map (DATA_IN(11 downto 8), SEL(1 downto 0),
INTERNAL(1));
    U4 : MUX4TO1C port map (DATA_IN(15 downto 12), SEL(1 downto 0),
INTERNAL(0));
    U5 : MUX4TO1C port map (INTERNAL(3 downto 0), SEL(3 downto 2), DATA_OUT);
end STRUCT;

```

11. (8 points) If the NRE costs for FPGA and CBIC circuits are \$25,000 and \$166,000, respectively, and the cost of individual parts for FPGA and CBIC circuits are \$20 and \$6, respectively, what is the break-even manufacturing volume for these two types of circuits?

Let x be the number of parts. Then,

$$\$25,000 + \$20X = \$166,000 + \$6x$$

$$14x = 141,000$$

$$x = 10071$$

12. (2 points) _____Standard cells_____ are primitives that are all the same height and varying widths.

13. (3 points) The three types of primary design units are __entities__, __configurations__, and __packages__.